

Blade Brake Clutch Application Guide

P-1319
819-0465

Application Guide



 **Warner**[®]
Electric

An Altra Industrial Motion Company

Contents

Introduction.	2
Operation	2
Design Considerations	3
Installation.	7
Performing Maintenance on the Warner Electric BBC	8
Troubleshooting the Warner Electric BBC.	9
Warranty	Back Page

⚠ WARNING Failure to follow these instructions may result in product damage, equipment damage, and serious or fatal injury to personnel. When performing maintenance on either mowing deck or engine, the engine should be stopped and the spark plug wire should be disconnected.

I. Scope

This manual has been prepared by Warner Electric to assist manufacturers of outdoor power equipment in the selection, installation, operation, and troubleshooting of Warner Electric Blade Brake Clutches (BBCs). The information contained in this publication is to be considered a general guideline for incorporation of BBCs into outdoor power equipment such as walk-behind and ride-on mowers. As each application is unique, the suitability of a BBC for use in a particular machine can only be determined through appropriate testing.



II. Introduction

Warner Electric BBCs are typically used to control the rotation of the cutting blade(s) on walk-behind mowers. These machines are generally designed with a means to automatically stop the blade(s) when the operator releases an operator presence control. (See Note 1) Warner Electric BBCs help accomplish this design goal by providing a means to remove engine power from the blades and braking the blades to a stop while at the same time allowing the engine to continue to run.

Warner Electric BBCs provide superior operator convenience to "engine-kill" systems in which the blade(s) and engine both stop when the operator releases the operator presence control. With this system the operator must restart the engine each time he/she leaves the operator zone to perform such common tasks as clearing debris from the lawn or emptying the grass catcher.

Note 1: Reference applicable International and U.S. Standards such as ISO-5395, EN-836, CPSC # --- and ANSI/OPEI B71.1.

III. Operation

The clutch is engaged by actuating the operator presence lever and pushing the blade engagement handle. This action rotates the ball ramp mechanism, causing three small internal springs inside of the clutch/brake to lift the brake plate clear of the friction disc. As the brake plate is released from the friction disc, a heavy coil spring at the base of the unit pushes the friction disc against the rotating input hub, which is bolted to the engine's crankshaft. The clutch is then engaged and the blade rotates. Releasing the operator presence lever causes the spring to rotate the ball ramp mechanism in the opposite direction which forces the brake plate against the outer portion of the friction disc, releasing the clutch and braking the blade to a stop.

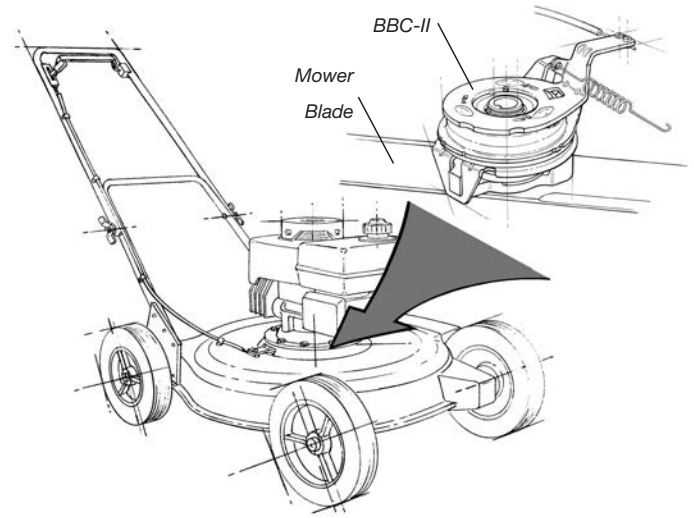
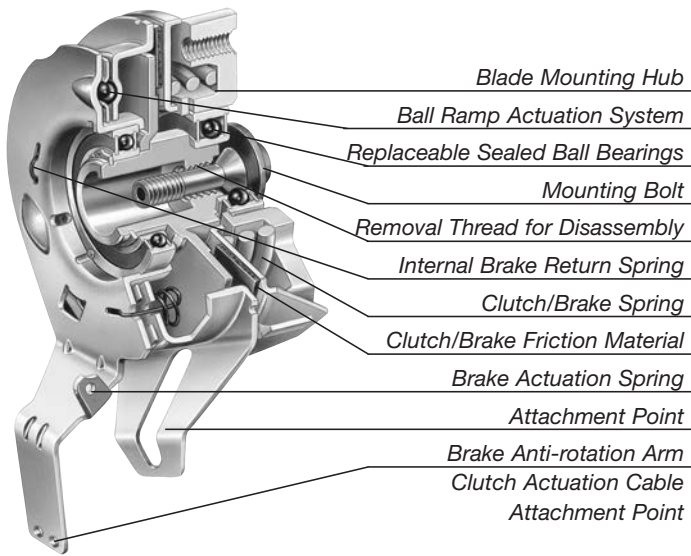

IV. Design Considerations

A. Mounting

Blade Brake Clutches are typically mounted directly to the engine crankshaft. BBCs are available in a shaft end or shoulder mounting configurations.

1. Shaft End Mounting

A shaft-end mounting configuration is shown in figure 1. The end of the engine crankshaft bottoms in the bottom of the bore in the BBC. With this type of mounting there must be clearance between the BBC hub and the ground drive pulley. The runout of the end of the engine crankshaft should be held to a maximum of 0.001 inches (0.025mm) to minimize the runout of the blade.

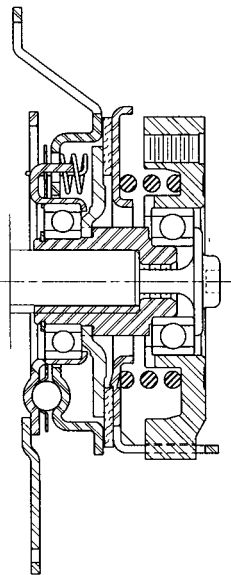

Figure 1

2. Shoulder Mounting

A shoulder mounting configuration is shown (Figure 2). The inner race of the top plate bearing is in contact with a shaft shoulder, spacer, or traction drive pulley. Clearance must be maintained between the end of the crankshaft and the bottom of the bore (2mm + 0 -1mm). With this style of mounting the shoulder runout should be held to a maximum of 0.001 inches (0.025mm) and the parallelism across a spacer or ground drive pulley should also be held to a maximum of 0.001 inches (0.025mm). Ground drive must be chamfered to clear the radius of the crankshaft. Pulley machining and chamfer to be done in one chucking.

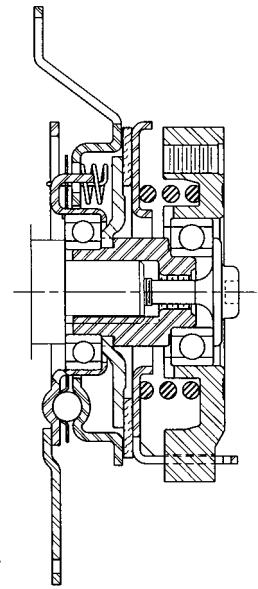

Figure 2

B. Mounting Bolt Torque

The mounting bolt not only retains the BBC on the crankshaft but also generates clamping force to prevent fretting corrosion between internal BBC components.

Recommended Bolt Torque		Thread Type
48 ± 3 lbs.ft.	65 ± 5NM	3/8-24 UNF
48 ± 3 lbs.ft.	65 ± 5NM	M10X1.25-6g

Bolt to be grade #8 US, Grade #10 Europe.

Note: Please contact Warner Electric for assistance with other thread sizes.

Table 1

To obtain proper bolt torque (See Table 1), the engine shaft must be held from rotating. Check with the engine manufacturer for acceptable methods of preventing shaft rotation. See figure 3 for piston stop used to prevent engine rotation.

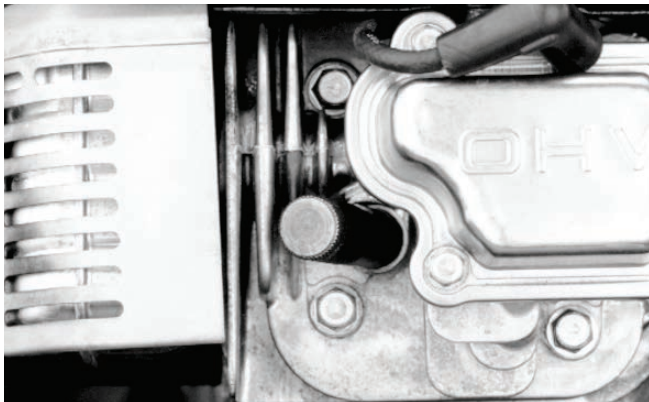

Figure 3

If customer supplied bolt and washer is used washer to be 3MM (0.118") thick and bolt to be grade 10 Europe (grade # 8 US bolt). Do not use lock washer.

The use of Loctite or other thread-locking adhesive is not recommended and is not a substitute for proper mounting bolt torque.

⚠ WARNING Proper mounting bolt torque is essential for BBC operation and to prevent premature failure of the BBC.

C. Anti-Rotation

BBC installations require an anti-rotation device to prevent the brake plate from rotating. The anti-rotation device should be rigidly mounted to the mower deck or engine block. The anti-rotation device must be designed to allow the brake plate to move axially. Warner Electric recommends that the anti-rotation device be fabricated from a .469 inch (11.9mm) nominal hardened steel pin.

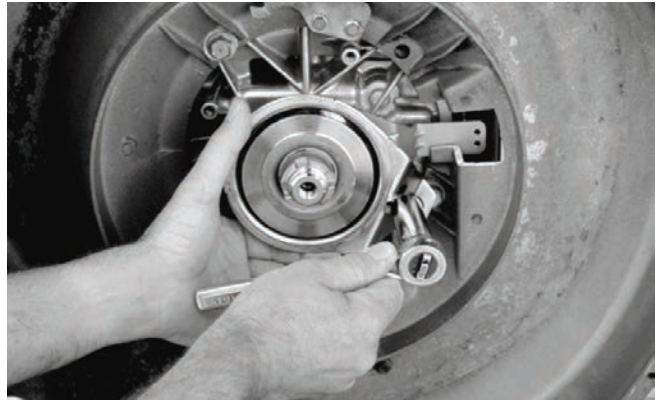

Figure 4

⚠ WARNING Constraining the axial movement of the brake plate may cause the BBC to function improperly, leading to increased blade stop times and premature failure of the BBC.

D. Brake Actuation Spring

The actuating force for the braking function is generated by a spring connected between the brake spring attachment point (or one of the clutch actuation cable attachment holes) and a rigid location on the mower such as the deck or engine block. Return spring is not provided with the BBC.

The total rotation of the actuation arm from the positive stop in the clutched position to the positive stop in the braked position is 17° nominal. A minimum of 150 in.lbs (16.95nm) of torque is required to move the actuation arm from the fully clutched to the fully braked position. The spring force required to achieve this torque is dependent on several factors such as the location of the attachment points, the angle of the spring compared to the plane, and the tangent of rotation.

Figure 5 shows typical brake actuation return spring mounting configuration. In figure 5, a spring that provides a force of 60-lb (27kg) tangent to ($\pm 12^\circ$) and in plane with the actuation arm rotation is attached at the brake spring attachment point [located on a 2.56-inch (66.04 mm) radius from the centerline of the BBC].

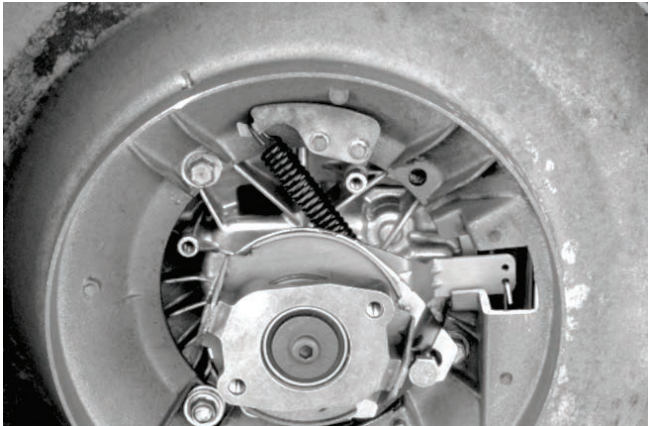

Figure 5

Option 2: When brake spring is attached to one of the holes in the actuator arm, it should provide a minimum of 12kg (26lb) force tangent to and in plane of rotation. When BBC is in clutch mode this spring force is not to exceed 20kg (44lb).

⚠ WARNING The blade brake feature of the BBC requires a brake return spring that will provide sufficient force to rotate the actuation arm to the positive stop in the braked position. Failure to fully rotate the actuation arm to the positive stop for the brake may result in increased blade stop time and/or premature BBC failure.

E. Clutch Actuation

A control system must be provided which will allow the operator to engage the clutch by rotating the actuation arm from the fully braked position to the fully clutched position. This is typically accomplished with a control in the operator zone, which is connected by a cable to the actuation arm. The control and cable assembly must have sufficient stroke to rotate the actuation arm from the positive stop in the braked position to the positive stop in the clutched position (17° nominal). Warner Electric recommends the use of a cable with an over-travel spring which will allow for mower manufacturing tolerances. Cable manufacturer to provide cable that will not stretch at required force and to add strands as required.

F. Clearance

Adequate clearance for all parts of the BBC is necessary for the BBC to function properly. No member of the BBC should be constrained by the mower deck, engine housing, or ground drive pulley. Adequate clearance should be available so that the brake plate may move axially up to .375 inches (9.5mm) and the clutch actuation lever may complete its required stroke (dimension varies for different BBC geometries; consult Warner Electric for assistance).

G. Engine Oil Drain Plug

All walk behind lawnmower engines contain an engine oil drain plug somewhere on the block. Some have the oil drain plug located directly above the BBC. When using these types of engines, Warner Electric strongly suggests that the end user of the lawnmower be clearly instructed to remove the engine oil out of the downspout, and not the engine oil drain plug.

⚠ WARNING

If engine oil is spilled onto the BBC, the BBC will not perform properly. The blade engagement time as well as the blade stop time may be severely increased. If engine oil is spilled on the BBC, it should be replaced.

H. Operating Temperature

Warner Electric's BBC is designed to operate in environments where the top plate bearing temperature does not exceed 250° F (121°C). We strongly recommend that the top plate bearing temperature be monitored during testing and any readings over 220° F (104°C) be reported to Warner Electric.

I. Torque Capacity

The BBC must have adequate clutch torque capacity to stall the engine in the event that the deck becomes blocked. The BBC is available with three different clutch springs for static torque capacities of 100, 144, and 160 in.lbs. (11.3, 16.3, & 18 NM). The BBC is generally applicable through 6 hp engines, however the torque output of engines can vary widely.

Warner Electric strongly recommends that during testing the stall capacity of the BBC be checked. Blocking the blade with a wooden board and repeatedly engaging the BBC against the blocked blade can easily accomplish this. We recommend the BBC should be capable of stalling the engine five consecutive times over a two-minute period. However, the mower manufacturer should establish the minimum number of times the BBC should be capable of stalling the engine based on the anticipated consumer usage. It is recommended that the stall testing be conducted immediately after the mower has run for at least one half hour and the BBC cycled at least 20 times.

J. Shrouds

Warner Electric recommends that the BBC not be enclosed in a shroud. Historically, shrouds have tended to trap grass clippings, debris and moisture around the BBC rather than protecting the BBC from contamination.

K. Blade Design

It is important that the mower blade be designed so that its natural frequency is above 60Hertz given a maximum engine speed of 3600 rpm. Failure to do so can result in very high blade deflections when the blade is stationary and the engine is running. The mower manufacturer should test for blade deflection over the entire engine speed range.

L. Deck Maintenance

Warner Electric strongly suggests that customers “**DO NOT**” use a pressure washer to clear the underside of the deck.

M. Engine Inertia

In some cases when using "engine kill" type operator presence controls, the engine manufacturers use the blade inertia as portion of the flywheel effect needed to start the engine. When using the BBC, the blade does not rotate when starting the engine. Some engines will require that a heavier flywheel be specified when using the BBC. Please consult with the engine manufacturer when specifying an engine that will be used with a BBC equipped mower.

V. Installation

The following describes a general procedure for installing a BBC on a mower. Some machines may require deviation from this procedure. In some cases due to the mower configuration, the BBC must be partially assembled to the engine before the engine is assembled to the deck.

1. Apply a small amount of rust inhibitor to the engine crankshaft.
2. If using a loose key, place the key into the key-slot in the engine shaft.
3. Align the key and keyway and slide the BBC onto the engine shaft. Use care not to contaminate the BBC friction surfaces with rust inhibitor.
4. Insert the mounting bolt supplied with the BBC through the clearance hole in the BBC into the threaded hole in the end of the engine crankshaft and hand tighten.
5. While preventing the engine shaft from rotating, torque (Figure 6) the mounting bolt to the appropriate torque specification. (See Table 1, page 4)
6. Install and tighten the anti-rotation bolt.
7. Install the clutch actuation cable.
8. Install the brake return spring. Reference Sec # IV - D. Check to be sure that the spring is strong enough to force the actuation arm to the positive brake stop. Push on the arm towards the brake stop. There should be no additional rotation of the arm. If the actuation arm rotates, it is indicative that the brake return spring is not strong enough. (Cable should be disconnected from deck attachment bracket at this time.)
9. Adjust the cable as necessary to ensure the actuation arm moves to the positive clutch stop. (See Figures 7A and 7B)
10. Install the mower blade.
11. Burnish the BBC per the procedure outlined in section VI Step C.

⚠ WARNING Failure to fully rotate the clutch actuation (See Figures 7A and 7B) arm to the positive stop may result in the clutch and brake being engaged at the same time resulting in drag on the engine and premature failure of the BBC.



Figure 6

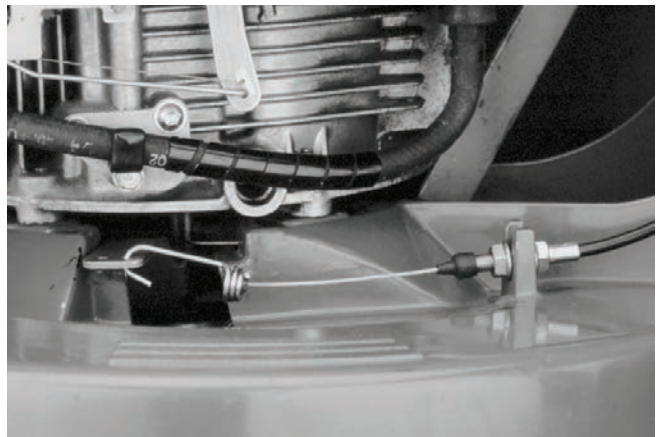

Figure 7A - Slack

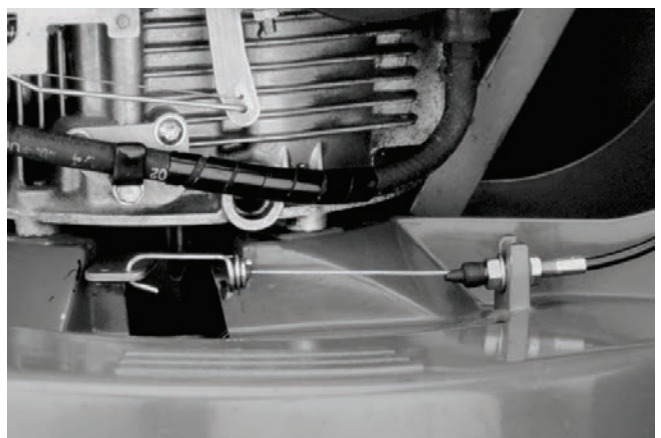

Figure 7B - Tight

VI. Performing Maintenance on the Warner Electric BBC

Please note that either the Troubleshooting Guide (see page 9) or a Warner Electric representative should be consulted to determine which component needs to be replaced.

A. Replacing the Output hub / Lower Assembly

1. Remove the lawn mower blade from the BBC by removing the blade mounting bolts.
2. Remove the lower assembly from the BBC. Install the new lower assembly to the BBC.
3. Check hub disc on upper assembly for excessive wear or discoloration (Blue/Straw etc.) this could indicate that the clutch has become overheated. If this is the case, replace the complete clutch. (See Table 1, page 4)
4. Reinstall the mower blade.
5. Burnish the BBC per the burnish instructions (see section VI. Step C.)

B. Replacing the complete BBC Assembly

1. Remove the lawn mower blade from the BBC by removing the blade mounting bolts.
2. Remove the brake actuation spring and remove the BBC mounting bolt.
3. Disconnect the BBC actuation cable.
4. Remove the complete BBC assembly using the removal threads.
Note: On some applications the BBC brake assembly will not easily fit through the space allowed in the mower deck. In this instance, the mower engine mounting bolts must be removed and the mower engine lifted off of the deck so that the brake assembly can be removed.

5. Install the new complete BBC assembly directly to the engine crankshaft. (See Section V) In the case where the mower engine was lifted up, remount the engine to the mower deck. (See Table 1, page 4)
6. Burnish the BBC per the burnish instructions (see Step C below).

C. BBC Burnish Instructions

Burnish the BBC whenever either the clutch assembly or the brake assembly is replaced without replacing the mating component. The mower should be fully functional before this burnish procedure is initiated. The burnish procedure consists of the following steps:

1. Start the lawn mower engine.
2. Run the mower engine at the maximum engine speed. Allow the mower engine to run a sufficient amount of time so that the engine will not stall upon engagement of the blade.
3. With the engine running at maximum engine speed, engage and disengage the BBC a minimum of 15 times.

V: Troubleshooting the Warner Electric BBC

Symptom: BBC will not engage or is slow to engage

Problem	Possible Causes	Section Referral/Solution
Clutch and brake are engaged at the same time	Cable is out of adjustment	Readjust the BBC actuation cable. (Refer to Section V #9)
Friction material is contaminated	Engine oil has infiltrated the friction material Grass or dirt has lodged around the friction material	If engine oil has been leaking onto the friction surfaces, replace the BBC immediately. If grass or dirt has lodged around the friction material, disassemble and remove the clutch assembly (See Section VI A & B) and remove the contaminants. (Refer to Section IV G)
Mounting bolt torque is inadequate	Mounting bolt improperly installed	Torque the mounting bolt to the specified installation torque. (Refer to Section VI A & B)
Overloaded clutch	Application is improperly sized	Consult Warner Electric personnel for assistance.
Friction material is worn out	BBC has surpassed its life	Replace the clutch assembly or the entire BBC. (Refer to Section VI A)

Symptom: BBC will not brake the mower blade

Problem	Possible Causes	Section Referral/Solution
Clutch and brake are engaged at the same time	Cable is out of adjustment	Readjust the BBC actuation cable. (Refer to Section V #9)
Anti-rotation device has failed	Anti-rotation device is missing or failed during mower operation	Replace the anti-rotation device. Inspect the BBC closely for damage and replace if necessary. (Refer to Section IV C)
Friction material is contaminated	Engine oil has infiltrated the friction material Grass or dirt has lodged around the friction material	If engine oil has been leaking onto the friction surfaces, replace the BBC immediately. If grass or dirt has lodged around the friction material, disassemble and remove the clutch assembly (See Section VI A & B) and remove the contaminants. (Refer to Section IV G)
Brake return spring is improperly installed	Installed incorrectly at the manufacturing site or by service personnel	Reinstall the brake return spring per the lawnmower manufacturer's specifications. (Refer to Section IV D)
Overloaded brake	Application is improperly sized	Consult Warner Electric personnel for assistance.
Mounting bolt torque is inadequate	Mounting bolt improperly installed	Torque the mounting bolt to the specified installation torque. (Refer to Section IV A & B)
Friction material is worn out or glazed	BBC has surpassed its life, cable out of adjustment, or brake spring too weak.	Replace the brake assembly/the entire BBC, or replace brake spring/adjust cable. (Refer to Section V A & B)

Quick Review Check List for BBC Applications

- 1 Check Mounting:
 - A. Shaft End Mounting: must have clearance between BBC hub and ground drive pulley, shaft end runout to be 0.001 inches maximum.
 - B. Shoulder-mounting: Inner race of top plate bearing is in contact with crankshaft shoulder, spacer or ground drive pulley. Clearance must be maintained between the bottom of the BBC bore and the end of crankshaft. Shoulder runout to be held to maximum 0.001 inches and parallelism across a spacer or ground drive to be held to maximum 0.001 inches

- 2 Mounting Bolt Torque: 48 lbs.ft. \pm 3 lbs.ft. (65NM \pm 5NM) (3/8-24 UNF or M10X1.25-6g) Make sure the mounting bolt does not bottom in crank threaded bore.

- 3 Anti-rotation: anti-rotation device allows axial movement of BBC. Min. pin dia. 0.469"
Note: Perform Steps 4 & 5 (of this check list) before return spring and cable are attached.

- 4 Position actuation arm so that BBC is in the full braked position, then mark leading edge position on deck.

- 5 Position actuation arm so that BBC is in the full clutched position, then mark leading edge position on deck.

- 6 Clearance: Adequate clearance for all parts of the BBC in both braked and clutched modes. Insure that the BBC does not bind or rub on any part of mower.

- 7 Attach Brake Actuation Spring: Brake actuation spring must have enough force to rotate the brake plate to the fully braked position.(See Step # 4, of this check list)

- 8 Control Cable: Control cable must have sufficient stroke to rotate the actuation arm from the positive stop in the braked mode to the positive stop in the clutched position (adjust if necessary). (use of an over travel spring will allow for cable stretch and manufacturing tolerances. (See Steps # 4 & 5, of this check list)

- 9 Engine Oil Drain plug: Instruct end user to remove oil from the filler tube and not from drain plug. Do not allow oil to contaminate BBC, replacement of BBC will be required if oil contamination occurs.

- 10 Operation temperature: Top plate bearing not to exceed 220 degrees F.

- 11 Shrouds: Warner Electric does not recommend the use of shrouds.

- 12 Blade design: Blade design to be designed so that its natural frequency is above driving frequency of engine.

- 13 Engine inertia: Fly wheel of sufficient size to allow for starting without the added inertia of the blade.

Warranty

Warner Electric LLC warrants that it will repair or replace (whichever it deems advisable) any product manufactured and sold by it which proves to be defective in material or workmanship within a period of one (1) year from the date of original purchase for consumer, commercial or industrial use.

This warranty extends only to the original purchaser and is not transferable or assignable without Warner Electric LLC's prior consent.

Warranty service can be obtained in the U.S.A. by returning any defective product, transportation charges prepaid, to the appropriate Warner Electric LLC factory. Additional warranty information may be obtained by writing the Customer Satisfaction Department, Warner Electric LLC, 449 Gardner Street, South Beloit, Illinois 61080, or by calling 815-389-3771.

A purchase receipt or other proof of original purchase will be required before warranty service is rendered. If found defective under the terms of this warranty, repair or replacement will be made, without charge, together with a refund for transportation costs. If found not to be defective, you will be notified and, with your consent, the item will be repaired or replaced and returned to you at your expense.

This warranty covers normal use and does not cover damage or defect which results from alteration, accident, neglect, or improper installation, operation, or maintenance.

Some states do not allow limitation on how long an implied warranty lasts, so the above limitation may not apply to you.

Warner Electric LLC's obligation under this warranty is limited to the repair or replacement of the defective product and in no event shall Warner Electric LLC be liable for consequential, indirect, or incidental damages of any kind incurred by reason of the manufacture, sale or use of any defective product. Warner Electric LLC neither assumes nor authorizes any other person to give any other warranty or to assume any other obligation or liability on its behalf.

WITH RESPECT TO CONSUMER USE OF THE PRODUCT, ANY IMPLIED WARRANTIES WHICH THE CONSUMER MAY HAVE ARE LIMITED IN DURATION TO ONE YEAR FROM THE DATE OF ORIGINAL CONSUMER PURCHASE. WITH RESPECT TO COMMERCIAL AND INDUSTRIAL USES OF THE PRODUCT, THE FOREGOING WARRANTY IS IN LIEU OF AND EXCLUDES ALL OTHER WARRANTIES, WHETHER EXPRESSED OR IMPLIED BY OPERATION OF LAW OR OTHERWISE, INCLUDING, BUT NOT LIMITED TO, ANY IMPLIED WARRANTIES OF MERCHANTABILITY OR FITNESS.

Some states do not allow the exclusion or limitation of incidental or consequential damages, so the above limitation or exclusion may not apply to you. This warranty gives you specific legal rights and you may also have other rights which vary from state to state.

Changes in Dimensions and Specifications

All dimensions and specifications shown in Warner Electric catalogs are subject to change without notice. Weights do not include weight of boxing for shipment. Certified prints will be furnished without charge on request to Warner Electric.



Warner Electric
31 Industrial Park Road • New Hartford, CT 06057
815-389-3771 • Fax: 815-389-2582
www.warnerelectric.com