

PB Series Brake

PB-500 Heavy Duty

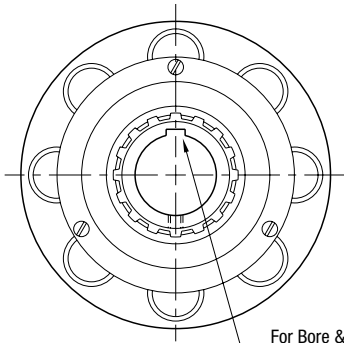

For Bore & Keyway sizes see chart below.

ARMATURE VIEW

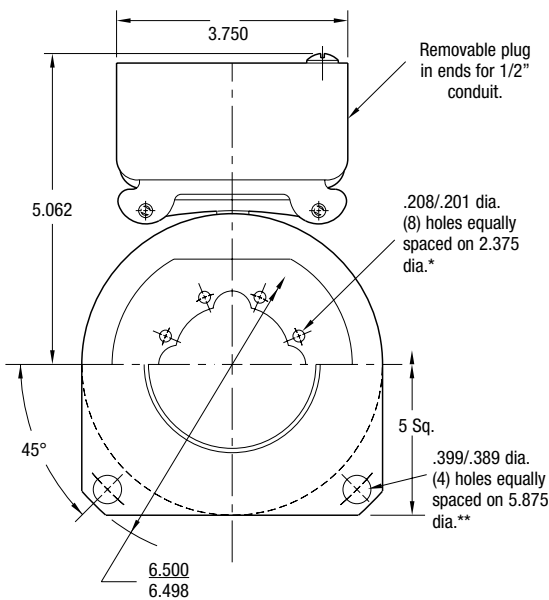

MAGNET VIEW

(Inside & Outside Mounted)

* Mounting holes are within .010 of true position relative to pilot diameter.

** Mounting holes are within .008 of true position relative to pilot diameter.

Customer Shall Maintain:

1. Squareness of brake mounting face with armature hub shaft within .006 T.I.R.
2. Concentricity of brake mounting pilot diameter with armature hub shaft within .010 T.I.R.

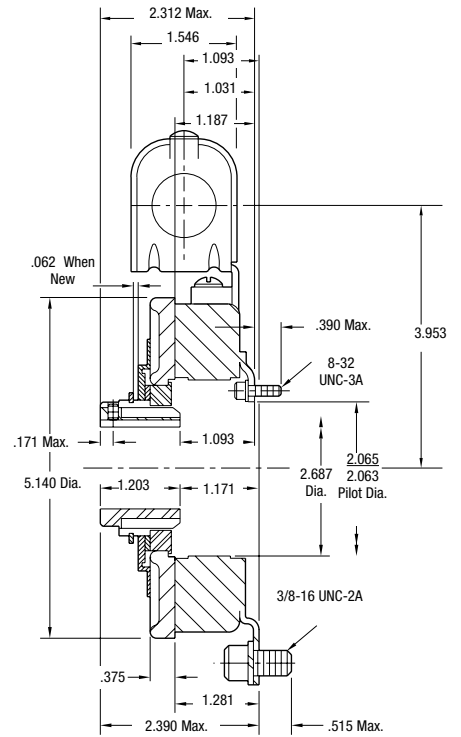

Outside Mounted Offset Backing Plate

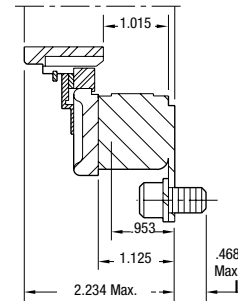

Outside Mounted Flush Backing Plate

Bore and Keyway Dimensions

Armature Bore Dia.	Keyway
.751/.750	.187 x .093
.876/.875	
.9385/.9375	
1.001/1.000	
1.126/1.125	.250 x .125
1.251/1.250	
Static Torque	40 lb.ft.
Maximum Speed	5,400 rpm
Standard Voltage	D.C. 6, 24, 90

All dimensions are nominal unless otherwise noted.

Information on inertia and weights begins on page 239. Coil data is on pages 250 and 251.



Drawing I-25550

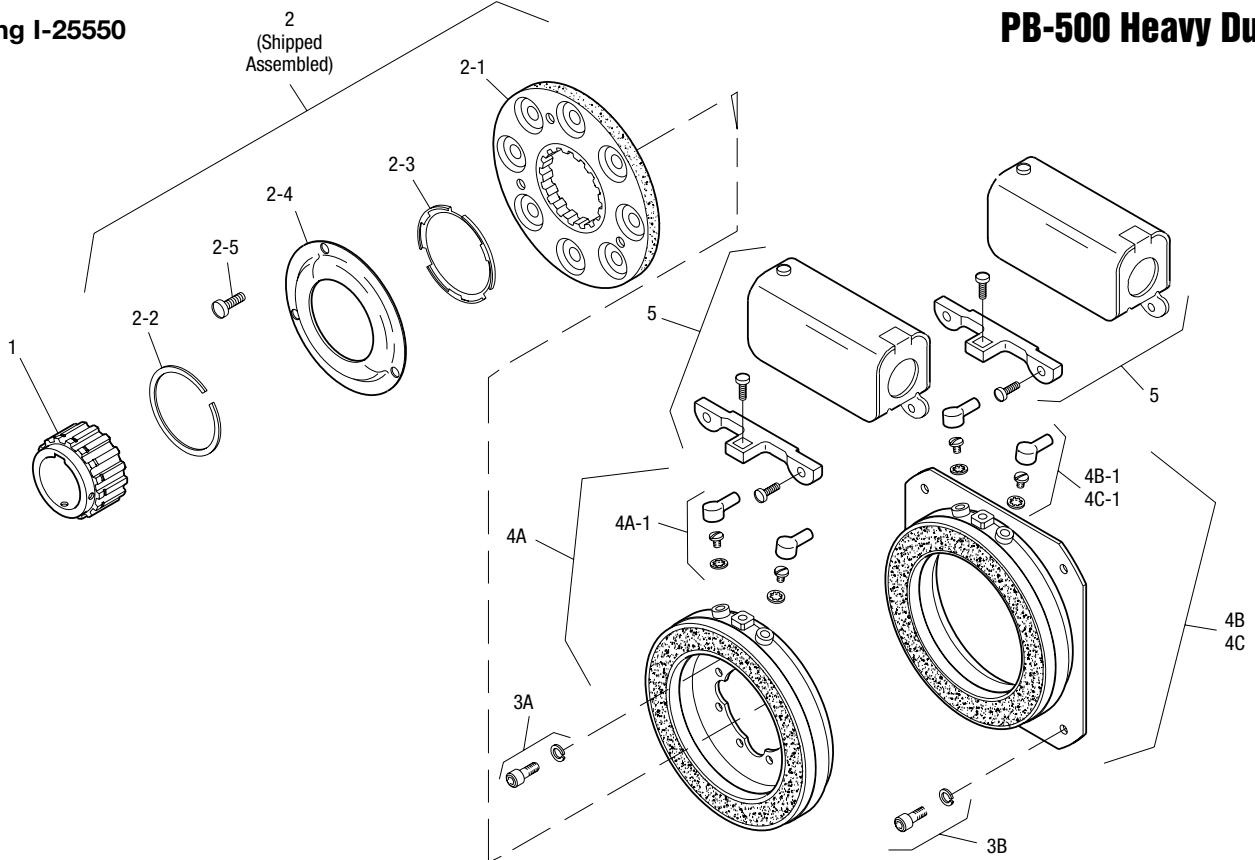

Item	Description	Part Number	Qty.
1	Armature Hub		1
	3/4" Bore	5200-541-002	
	7/8" Bore	5200-541-003	
	15/16" Bore	5200-541-004	
	1" Bore	5200-541-005	
	1-1/8" Bore	5200-541-006	
	1-1/4" Bore	5200-541-007	
	2	Armature Assembly	5230-111-002
2-1	Armature		1
	Segmented	5230-111-001	
	Solid	110-0076	
2-2	Retainer Ring	748-0355	1
2-3	Autogap Spring	808-0412	1
2-4	Retainer Plate	748-0364	1
2-5	Screw	797-0028	3
3A	Mounting Accessory - I.M.	5102-101-001	2
3B	Mounting Accessory - O.M.	5300-101-008	1
4A	Magnet - I.M.		1
	6 Volt	5300-631-002	
	24 Volt	5300-631-003	
	90 Volt	5300-631-005	
	†90 Volt LK Facing	5300-631-020	
4A-1	Terminal Accessory	5311-101-001	1

Item	Description	Part Number	Qty.
4B	Magnet - O.M. - Offset		1
	90 Volt	5300-631-014	
	†90 Volt LK Facing	5300-631-025	
4B-1	Terminal Accessory	5311-101-001	1
4C	Magnet - O.M. - Flush		1
	6 Volt	5300-631-009	
	24 Volt	5300-631-010	
	90 Volt	5300-631-011	
4C-1	Terminal Accessory	5311-101-001	1
5	Conduit Box	5200-101-010	1

How to Order:

1. Specify Bore Size for Item 1.
2. Specify Voltage for Item 4A, 4B, or 4C.
3. Specify Inside Mounted for Item 4A and Outside Mounted (Offset) for Item 4B or Outside Mounted (Flush) for Item 4C.
4. See Controls Section.

Example:

PB-500 Brake per I-25550 - 90 Volt, Inside Mounted, 1" Bore

These units, when used in conjunction with the correct Warner Electric conduit box, meet the standards of UL508 and are listed under guide card #NMTR, file #59164. These units are CSA certified under file #LR11543.

Refer to Service Manual P-0204-WE

†Optional LK facing available. For more information, see page 232.