

# PC Series Clutch

## PC-825 Normal Duty

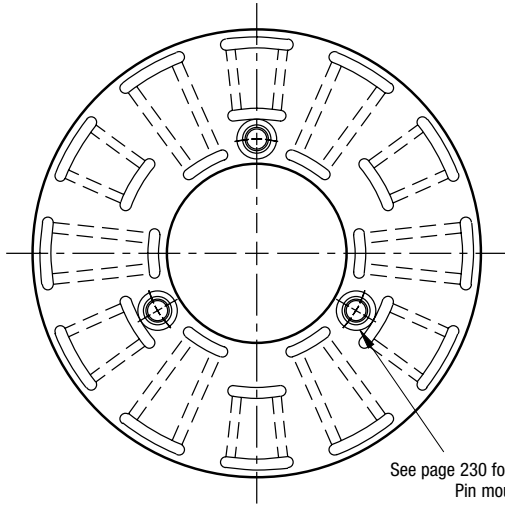

**ARMATURE VIEW**

See page 230 for details on Drive Pin mountings.

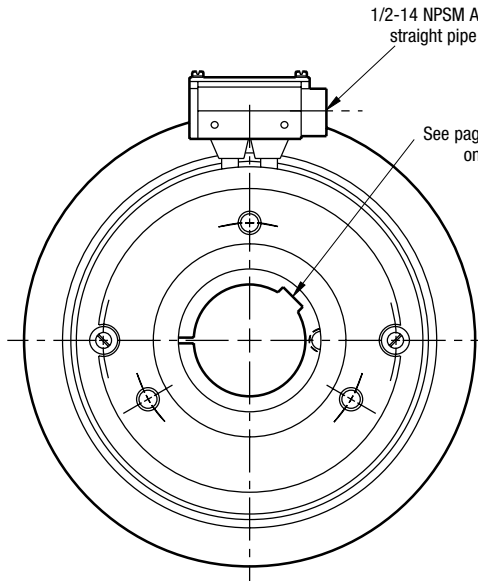

**COLLECTOR RING VIEW**

1/2-14 NPSM Am. std. straight pipe tap.

See page 252 for details on Bushings.

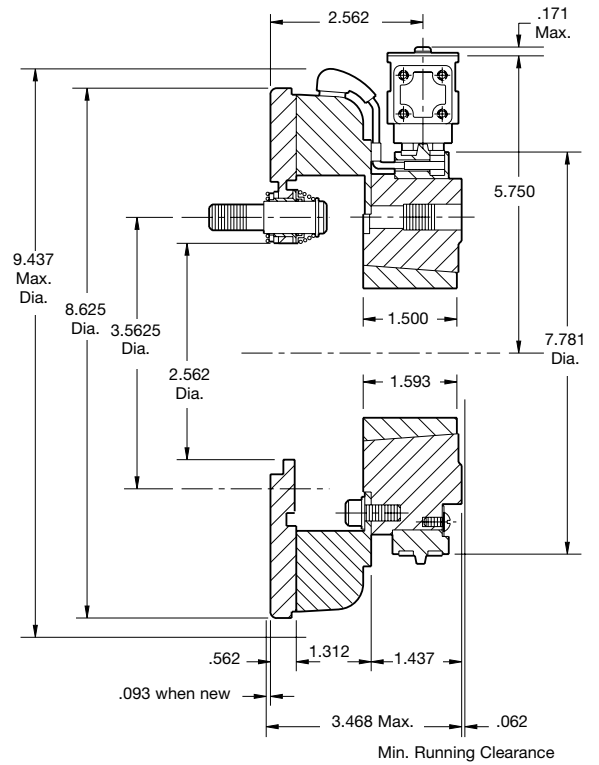

Shaft Size	.500 – 1.625
Static Torque	125 lb.ft.
Maximum Speed	4,000 rpm
Standard Voltage	D.C. 6, 24, 90

All dimensions are nominal unless otherwise noted.

Information on inertia and weights begins on page 239. Coil data is on pages 250 and 251.



Drawing I-25562

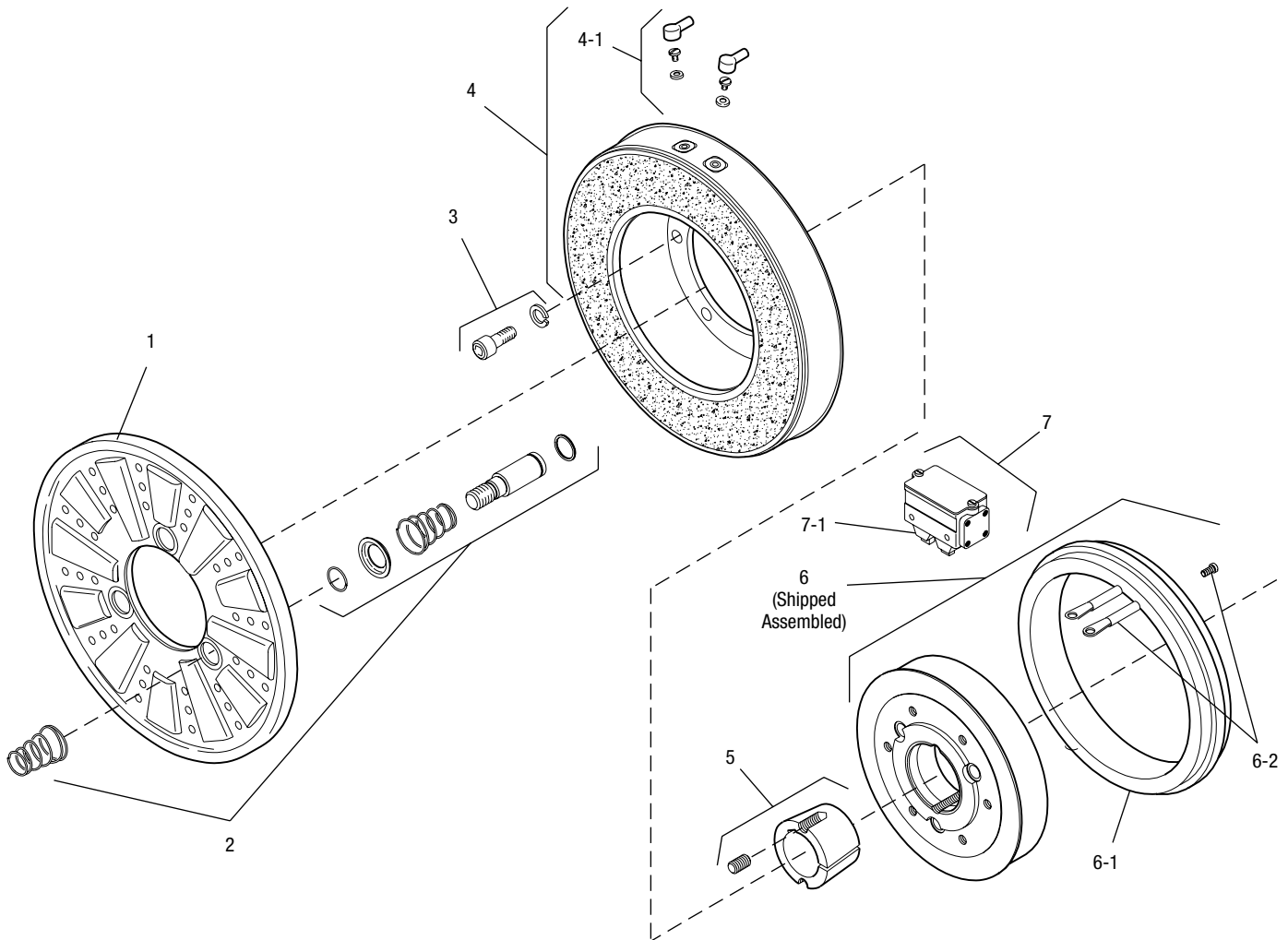

Item	Description	Part Number	Qty.
1	Armature	5301-111-018	1
2	Autogap Accessory	5201-101-008	3
3	Mounting Accessory	5321-101-001	1
4	Magnet		1
	6 Volt	5301-631-002	
	24 Volt	5301-631-004	
	90 Volt	5301-631-005	
	†90 Volt LK Facing	5301-631-011	
4-1	Terminal Accessory	5311-101-001	1
5	Bushing*		1
	1/2" to 1-5/8" Bore	180-0131 to 180-0149	
6	Magnet Hub		1
	Left Hand (shown)	5301-541-001	
	Right Hand	5301-541-002	
6-1	Collector Ring	5301-749-001	1
6-2	Collector Ring Accessory	5301-101-002	1
7	Brushholder	5300-178-001	1
7-1	Brush	176-0001	4

### How to Order:

1. Specify Voltage for Item 4.
2. Specify Bore Size for Item 5.
3. Specify left hand or right hand hub for Item 6. (Bushing enters from magnet side for L.H. hub and from hub side for R.H.)
4. See Controls Section.

### Example:

PC-825 Clutch per I-25562 - 90 Volt, L.H. hub, 1" Bore

These units meet the standards of UL508 and are listed under guide card #NMTR2, file #59164.

These units are CSA certified under file #LR11543.

\*See page 252 for specific part numbers.

Refer to Service Manual P-0206-WE

†Optional LK facing available. For more information, see page 232.